

NEXT GENERATION

EGON

48V

EXPLAINED

"This is not evolution. It's Revolution"

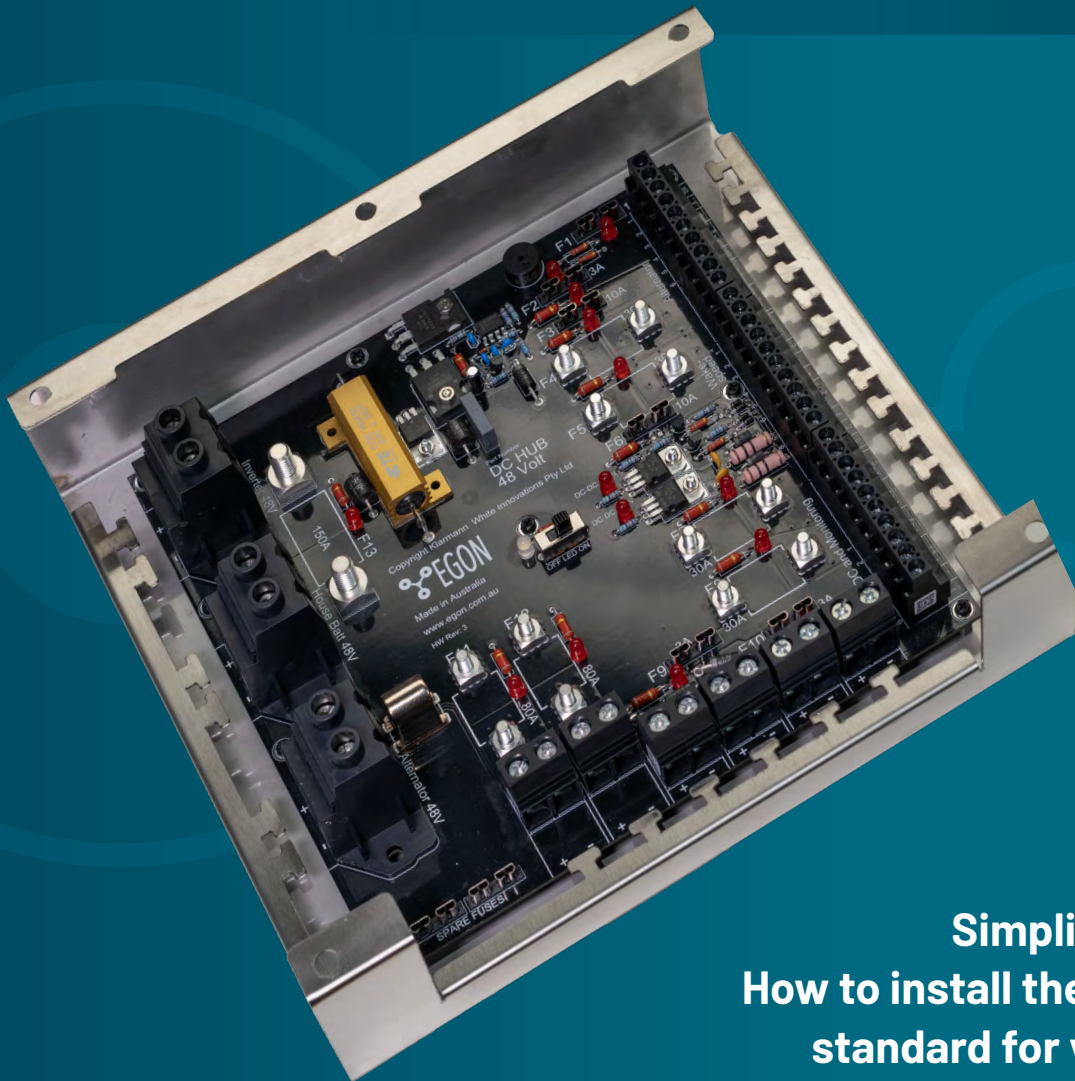

**Simplifying 48V.
How to install the new gold
standard for vehicle DC
installations.**



**GAME-CHANGING
SIMPLICITY**

THE NESPRESSO OF DC INSTALLATIONS

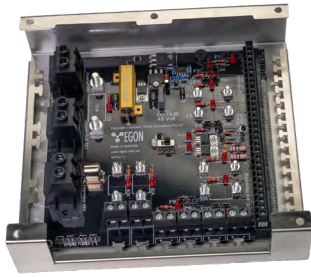

SAFETY BRIEFING

48V can harm you. Please watch this short safety video. . .



click the video thumbnail above.



We like to think of all EGON Hubs as the Nespresso of in-vehicle DC installations. To do something that's been done for decades, but altogether easier, faster, cheaper and just better at everything.

In terms of 48V, this really is a game-changing solution that for the very first time makes 48V accessible to everyone - with advantages none dare dream of with 12V - because with 12V, this level of performance is physically impossible.

- 48V** • 48W is 4-5 times more efficient.
- VS** • 48V was once 4-5 times more complex.
- 12V** • EGON has made 48V simpler and less costly than most high-end 12V systems.

HOW 48V CHANGES EVERYTHING

If we had limited words to describe the Egon DC-HUB 48V, they'd be



PLUG & PLAY



GAME-CHANGING



REMARKABLE

How Egon simplifies 48V:

- A single central hub
- Load dump protection for every component
- Connections for alternator controller and power
- Two connectors for 48-12V or 48V-24V converters
- In/Out connectors for 48V equipment (e.g trailer)
- Inverter connection up to 6kW.
- 48V house battery connector. Unlimited kWh
- Connectors for Cerbo-GX monitor
- Highest-quality screw clamps for easy connection of cables (no special tools needed.)

The Egon DC-Hub 48V turns once complex, expensive and sometimes risky 48V installations into a plug & play adventure. Which means 48V is now available to anyone doing traditional 12/24V installations. 48V is no longer the purview of the top shops. Anyone can enjoy the wonders of 48V and as importantly, any workshop can do this shit. And maintain it! **Do you want to be a leader in 48V? This is your chance.**

**GEAR THAT
YOU SHOULD
KEEP NEAR.**

Here's what you'll need:

- Reading glasses
- Screwdrivers
- Coffee
- Installation Guide
- Music you like
- Pat on the back for a job done fast (Optional, but highly suggested)

YOUR CUSTOMERS MIGHT ASK, WHY 48V?

➔ **If you could make your van, 4x4 or camper trailer battery charging 4+ times faster, would you?**

➔ **Would you like to never need shore power, ever again?**

1 Enter the EGON DC-Hub 48V

- Like all Egon power distributor boards that massively simplify DC installations, the DC-Hub 48V now tames the complex issues of installation, 48V alternators, reliability, redundancy and perhaps best of all, the ability for the ordinary mechanic to understand it.

2 Plug and play 48V. Literally.

- The Egon Hub 48V is a single central component that distributes charge and discharge energy from alternator, start battery, alternator controller, car systems, house batteries and even an inverter.
- The Egon Hub 48V enables the connection of commonly-used digital measuring devices and apps.
- An alternator controller communicates with the battery in real time.
- While any 48V house battery can be configured, EGON-certified 48V batteries are pre-programmed to control the alternator controller how they need to be charged.
- In-built load-dump controller protects all circuits and fitted equipment.
- Little expertise needed to wire it up. Follow simple instructions, no ferrules, crimps, heat-shrink and lugs required. Using multi-core cables, fitters must simply follow the numbers to connect components.
- No need for a DC-DC charger because the alternator controller and BMS does this job.
- 48V-12V converters feed the car and house 12V systems via the Hub.
- None of the car's electrics are changed, with the exception of the alternator. In most cases, no OE cabling is breached.

3 What about 12V alternators charging 48V batteries?

- Converting voltage down is easy and efficient. Converting up is costly and extremely lossy. Gains will then be limited to the discharge side of the batteries, and none on the charging side. In our opinion, it's rarely worth the expense given that most of the gains of 48V are produced on the charging side of the batteries.

FOR EXAMPLE, CHECK THIS OUT: CHARGE TIMES . . .



12V

Charging a battery capable of delivering 4,8kWh or 400a/h@12V, while driving and running the largest 12V alternator and DC-DC charger available (100A), will take, in theory, 4 hours. Though, in the real world, because of voltage drop along cables and connectors, add another hour at least.

48V

Now charge the same capacity 4,8kWh or 100a/h@48V through the EGON 48V hub, while running a mid-range 48V alternator (e.g.100A), in theory a drive time of 1 hour is required. Because the bottleneck or a DC-DC charger removed, with the significant decrease in voltage drop, our real world tests show that indeed, a one hour drive was all that was needed to charge a 4,8kWh battery. (Ambient 24°C, 75.4°F). Now we've charged this quickly, the energy can be delivered in both 48V and 12V via an inexpensive 48-12V converter to the 12V systems.

Now, a full-size 48V alternator in a truck, dozer or plant, the charge from 0-100% is complete before the engine is warm. This is a reality. And why the game is changing as you read this.

SAFETY

Under Australian legislation, like 12V, 48V lies in the 'Ultra Low Voltage' category. It is for this reason that working on 48V does not need certification. Even so, one should take additional precautions, because a shock, if absorbed, can be unpleasant and even painful. Following precautions is highly recommended:

- Isolate the batteries BEFORE any installation work is done and only connect the batteries when the installation is COMPLETE and wear RUBBER GLOVES to isolate one's hands to prevent possible shock when connecting the battery/s.
- Be especially aware that using a spanner to tighten or loosen a battery terminal, does not short out or touch the steel body of a vehicle.
- Never work on the system if one is wet, perspiring heavily, or standing bare-footed on the metal surface of a vehicle - unless the battery/s are isolated.
- If doing routine maintenance, like firming up the connectors with the battery/s connected, always use ELECTRICAL SAFETY SCREW-DRIVERS that have isolated handles and rods. Wear rubber gloves for additional protection.

WIRING DETAILS. FOLLOW THESE STEPS

1 MOUNTING AND CONNECTING THE 48V HUB.

- The EGON 48V hub is supplied with a stainless steel mounting bracket. Mount spacers in the bracket with screws inserted from the back. Do not over-tighten the screws. Just a firm hand will do.
- Mount the bracket in a dry and easily accessible location. (Nano is not suited to under-bonnet installations.)
- Insert the hub into its bracket and secure using the 8 spacers and screws.
- Place external battery fuses near each battery but do NOT insert fuses until installation is complete, or near completion (safety).
- Route and secure all cabling for alternator, alternator controller (Wakespeed), DC converters and loads.
- Using diagrams and instructions on the following pages, connect loads, converters, controllers, Cerbo GX and solar inputs to the 48V hub. Double check your work. I'll repeat that. **DOUBLE CHECK YOUR WORK BEFORE THE NEXT STEPS.** Do not connect batteries at this stage.
- Use cable ties to secure the cables to the T-bars on the mounting bracket. This is important as it reduces vibration wearing the cables loose.
- Insert each fuse step by step and check system behavior at every step.
- Verify polarity and connector torques. Connect the battery while using rubber gloves for protection. Then energize the system by installing the battery fuse/s. A small white LED on the 48V hub will indicate that the board is energized.

2 INSTALLATION AND WIRING DETAILS

If you connect everything exactly as explained, and check your work carefully, then the EGON 48V hub works every time, without exception. Be lazy, get a connection wrong, and it could damage a component. This is why it is **VITALLY IMPORTANT** that you check your work, and do **EXACTLY** what is shown here **BEFORE** you connect the battery. Should you decide to try 'a better way' and you cook something, then on your wallet be it. We'll help you get replacements, but honestly, this wiring works every time.

3 INSTALLING THE ALTERNATOR

Changing an alternator requires specialist knowledge and any competent auto electrician or mechanic should be able to do it. The drive belt will have to carry the additional work required by the high charge rates. Which means a less than competent job could lead to belt slippage and other issues. If you are doing a DIY installation, make sure that this vital step is done to the manufacturer's specifications.

GROUND CONNECTIONS TO THE ALTERNATOR AND VEHICLE

- 4 It is important that both ground connections are installed. One runs from the alternator and/or engine block to the hub. The second runs from the start battery to the hub. **BOTH** must be connected as shown in the diagrams. Do not be tempted to skip one of these ground connections.

INSTALLATION OEM ALTERNATOR REPLACEMENT

EGON 48 Volt Architecture for OEM Alternator replacement

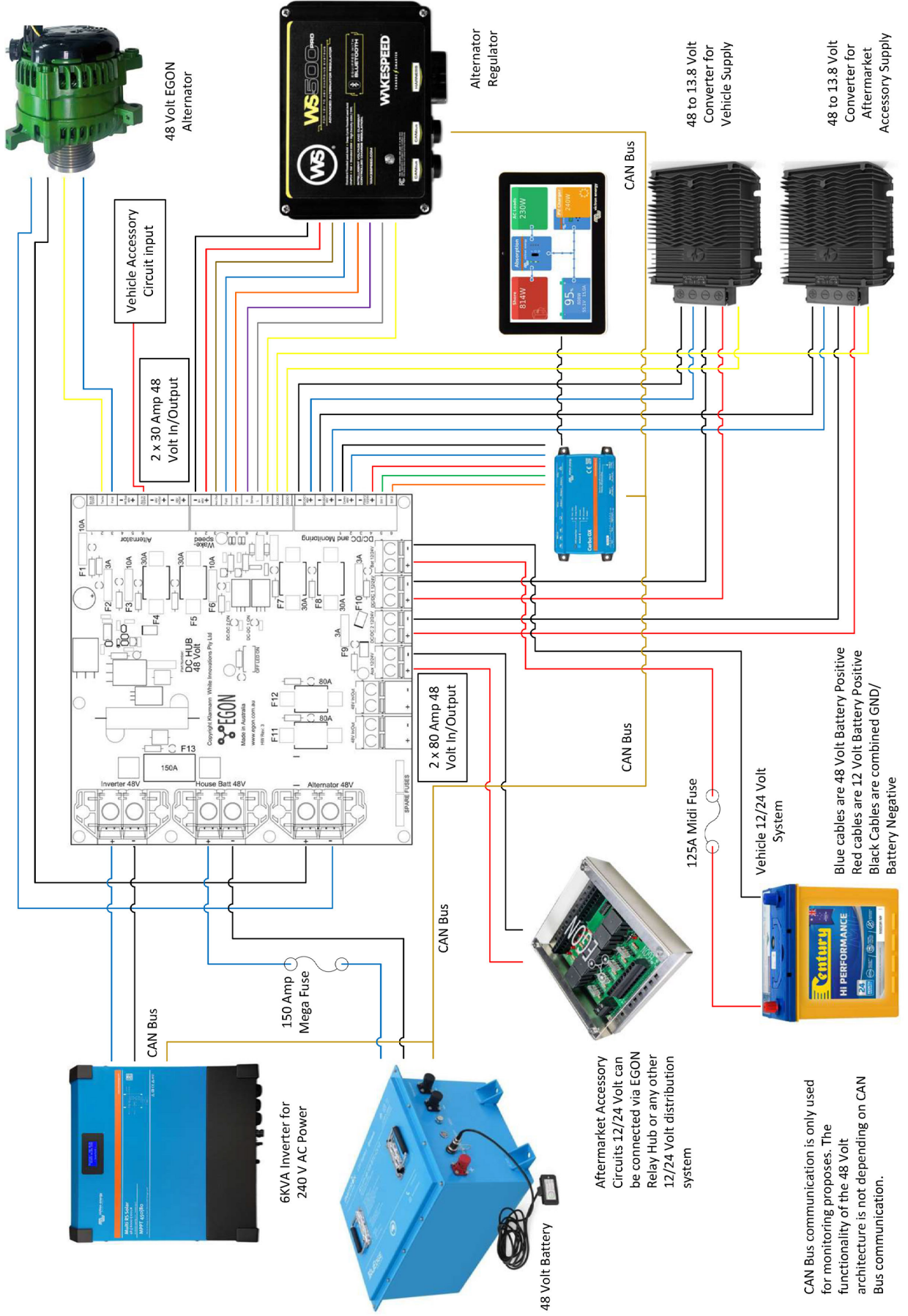

INSTALLATION DUAL ALTERNATORS

EGON 48 Volt Architecture for Dual Alternators

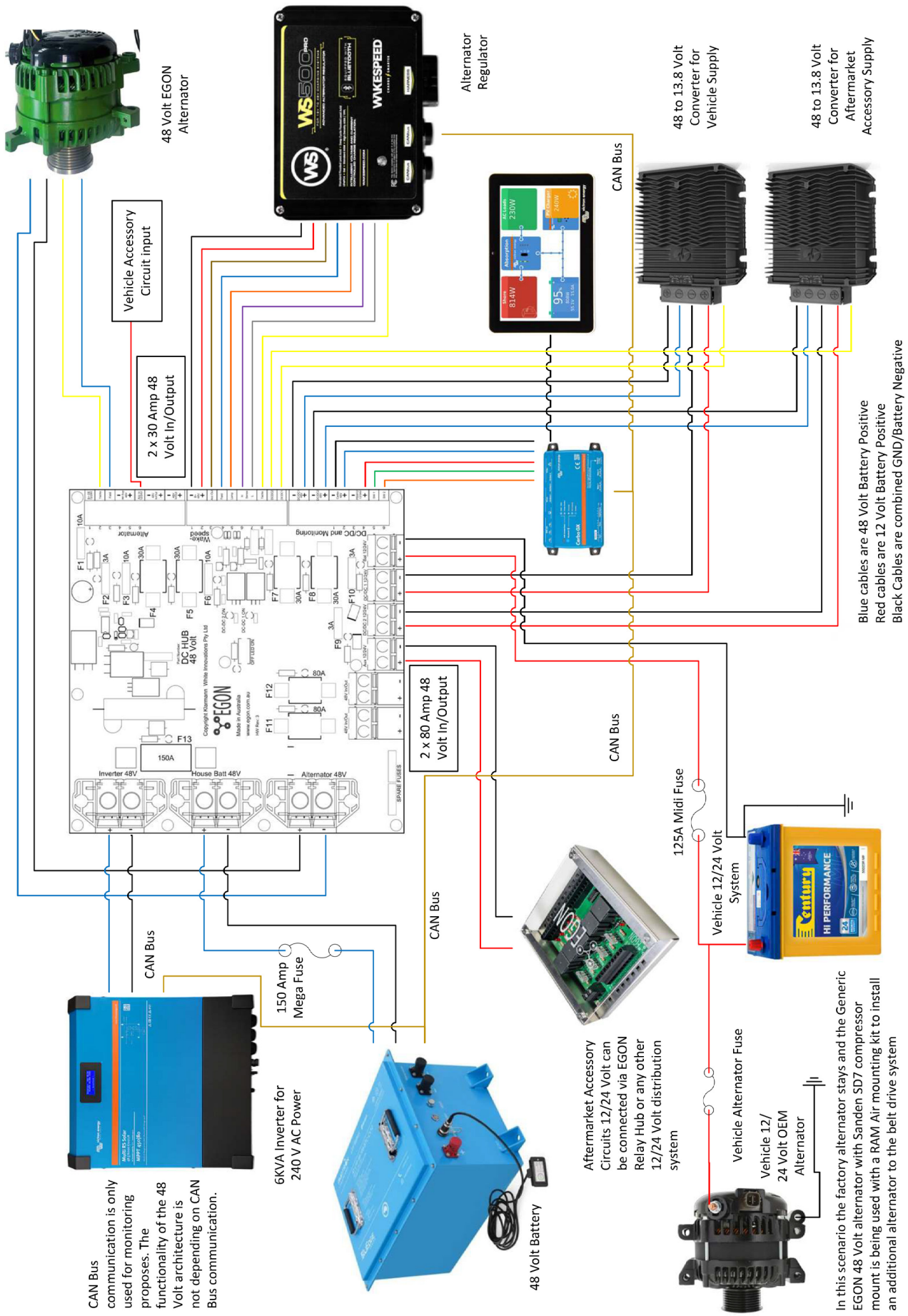

CAN Bus communication is only used for monitoring purposes. The functionality of the 48 Volt architecture is not depending on CAN Bus communication.

6KVA Inverter for 240V AC Power

150 Amp Mega Fuse

48 Volt Battery

Aftermarket Accessory Circuits 12/24 Volt can be connected via Egon Relay Hub or any other 12/24 Volt distribution system

Vehicle Alternator Fuse
Vehicle 12/24 Volt OEM Alternator

In this scenario the factory alternator stays and the Generic Egon 48 Volt alternator with Sanden SD7 compressor mount is being used with a RAM Air mounting kit to install an additional alternator to the belt drive system

Vehicle Accessory Circuit input

48 Volt Egon Alternator

WIKESPEED WS500 AMP ALUMINUM
ALTERNATOR REGULATOR

Alternator Regulator

48 to 13.8 Volt Converter for Vehicle Supply

48 to 13.8 Volt Converter for Aftermarket Accessory Supply

Blue cables are 48 Volt Battery Positive
Red cables are 12 Volt Battery Positive
Black Cables are combined GND/Battery Negative

48V IN/OUT & FEATURES

48 Volt In/Outputs and Features

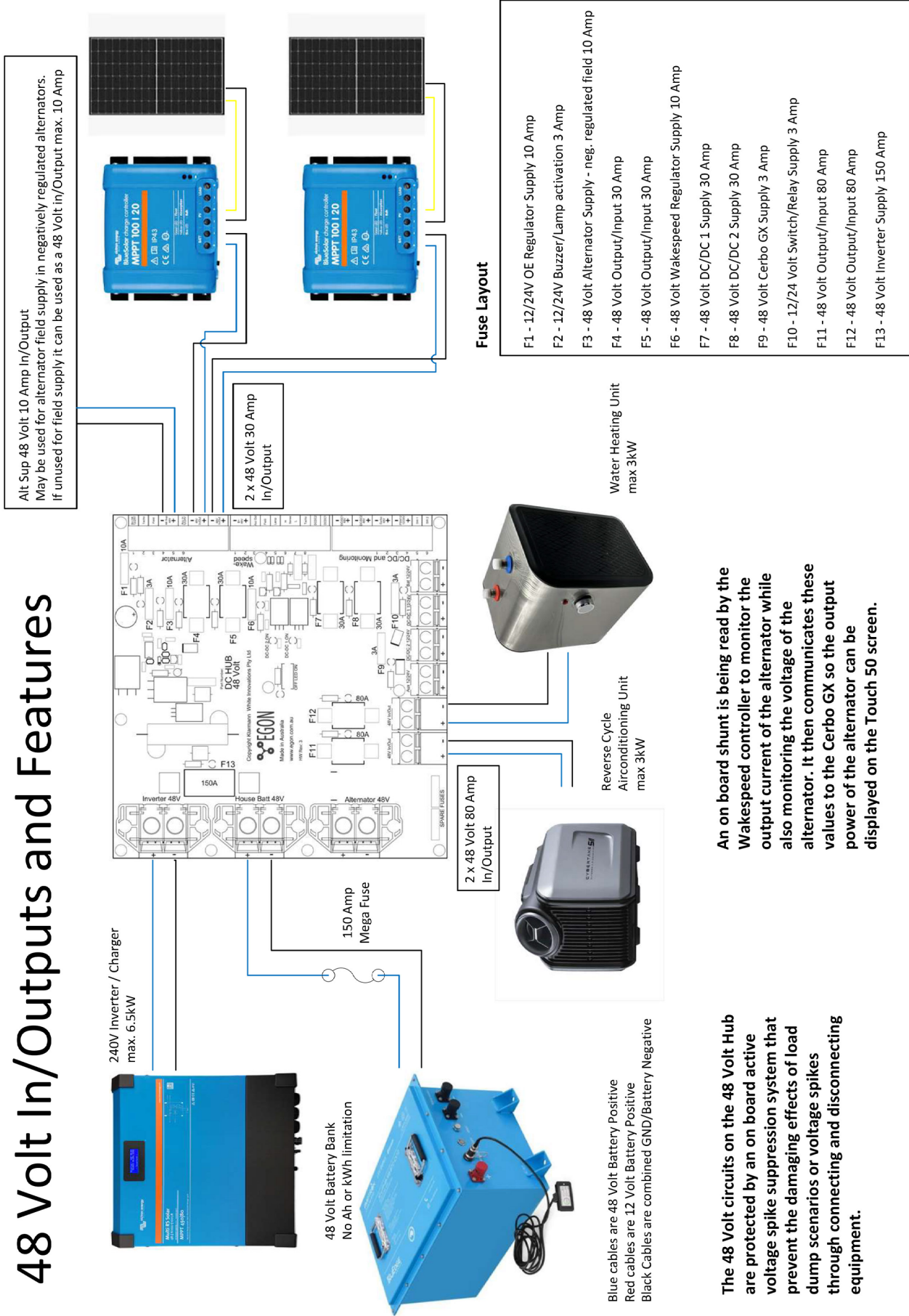

BATTERY START CIRCUITS

Start Battery Circuits

Wiring information: All Ground connections have to be run back to the power source. Body earth connections are not to be used and are only shown for simplification of the wiring diagram

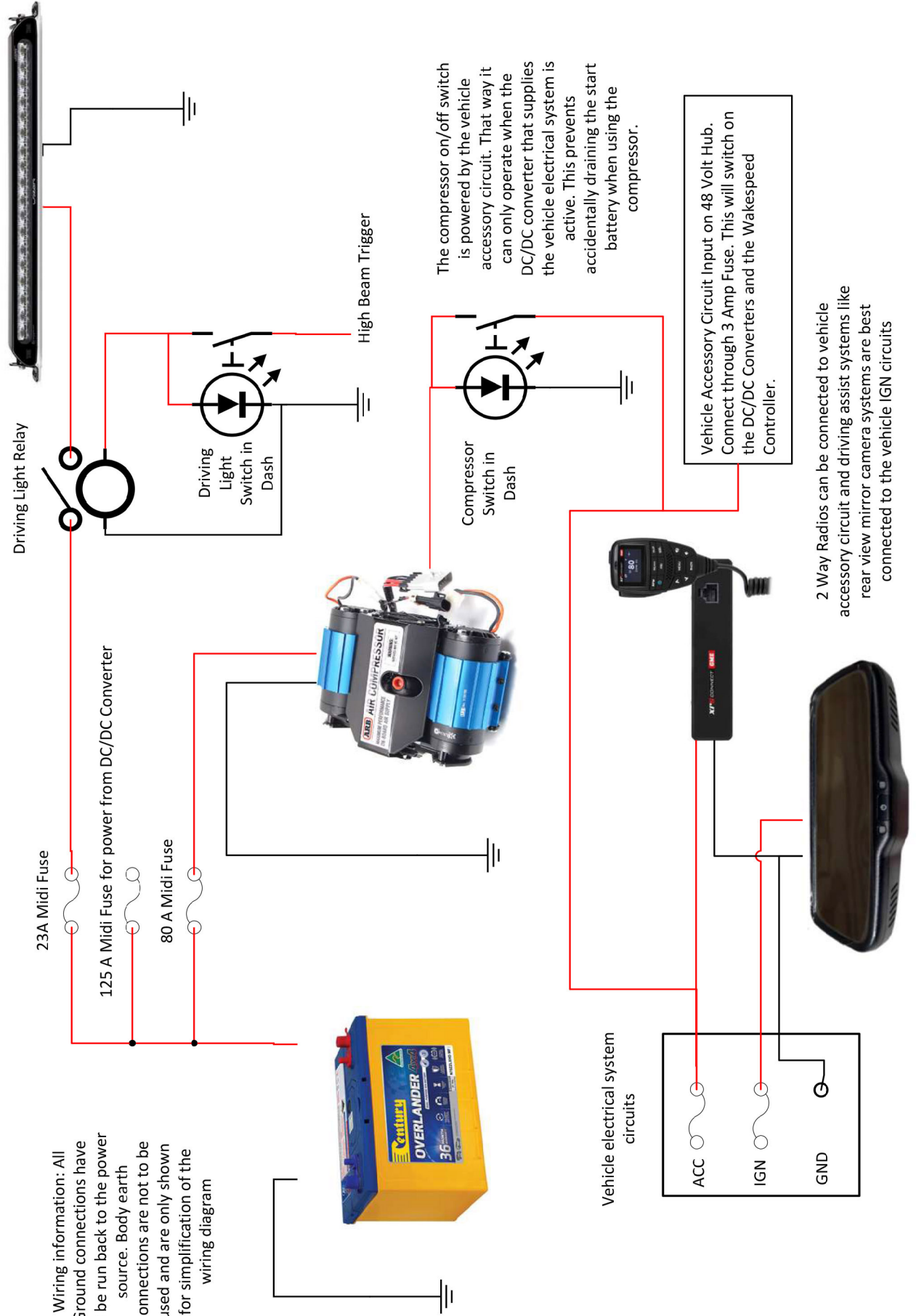

The compressor on/off switch is powered by the vehicle accessory circuit. That way it can only operate when the DC/DC converter that supplies the vehicle electrical system is active. This prevents accidentally draining the battery when using the compressor.

Vehicle Accessory Circuit Input on 48 Volt Hub. Connect through 3 Amp Fuse. This will switch on the DC/DC Converters and the Wakespeed Controller.

2 Way Radios can be connected to vehicle accessory circuit and driving assist systems like rear view mirror camera systems are best connected to the vehicle IGN circuits

Aftermarket Accessory 12/24 Volt Circuits

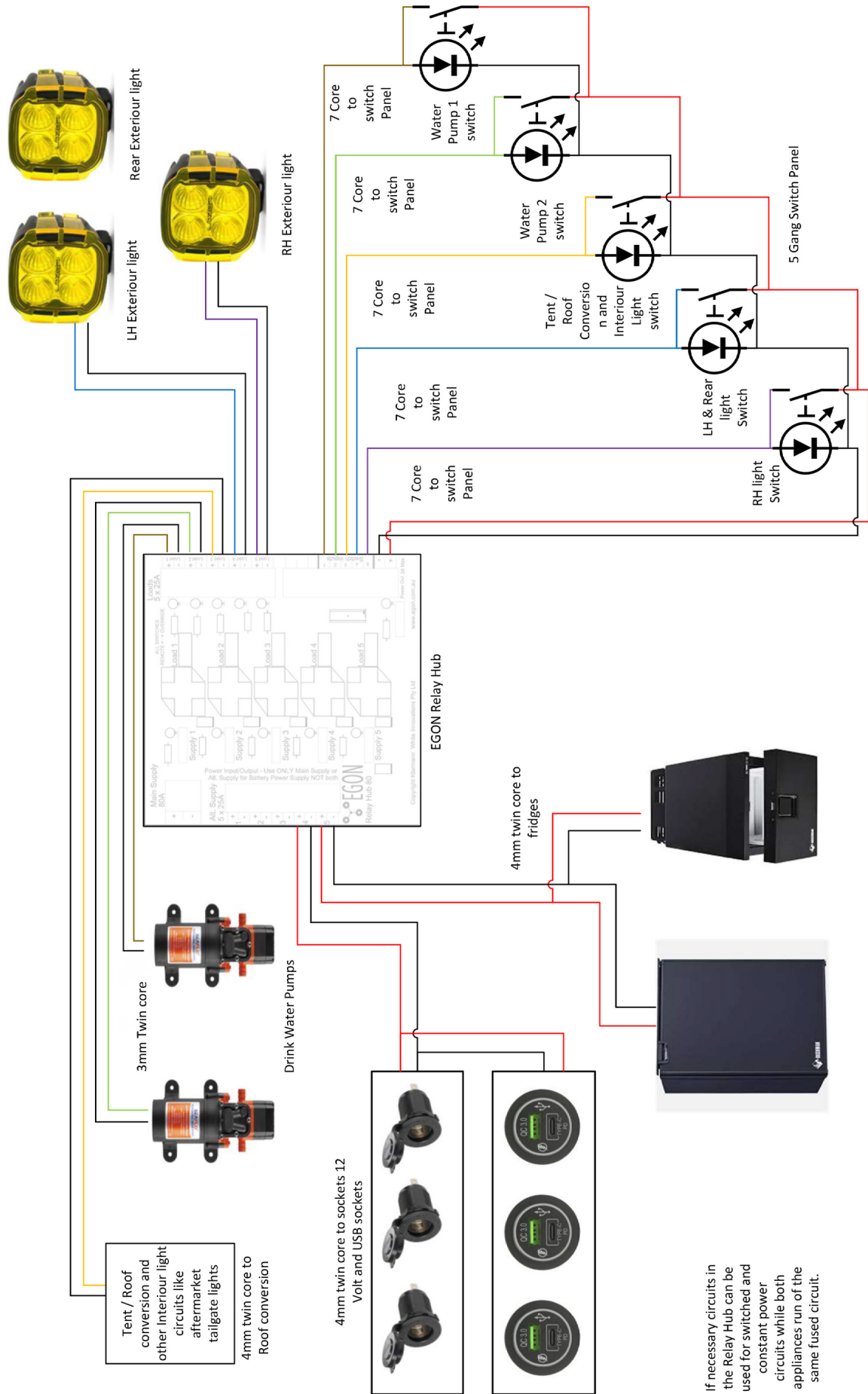

If necessary circuits in the Relay Hub can be used for switched and constant power circuits while both appliances run of the same fused circuit.

240V AC CIRCUIT EXAMPLES

AC 240V Circuits Examples

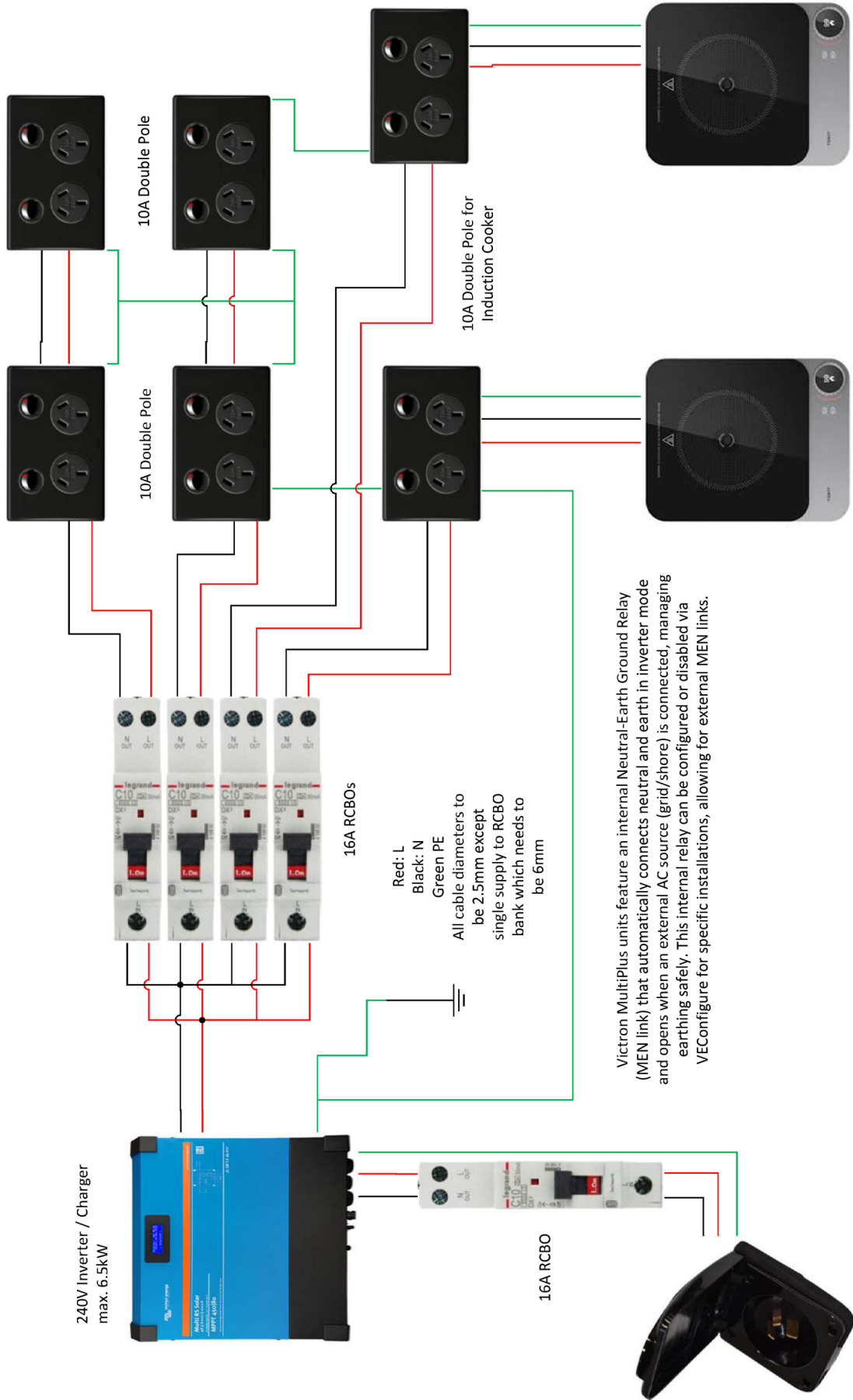

Water Plumbing and Water Level Circuits with EGON Water Hub

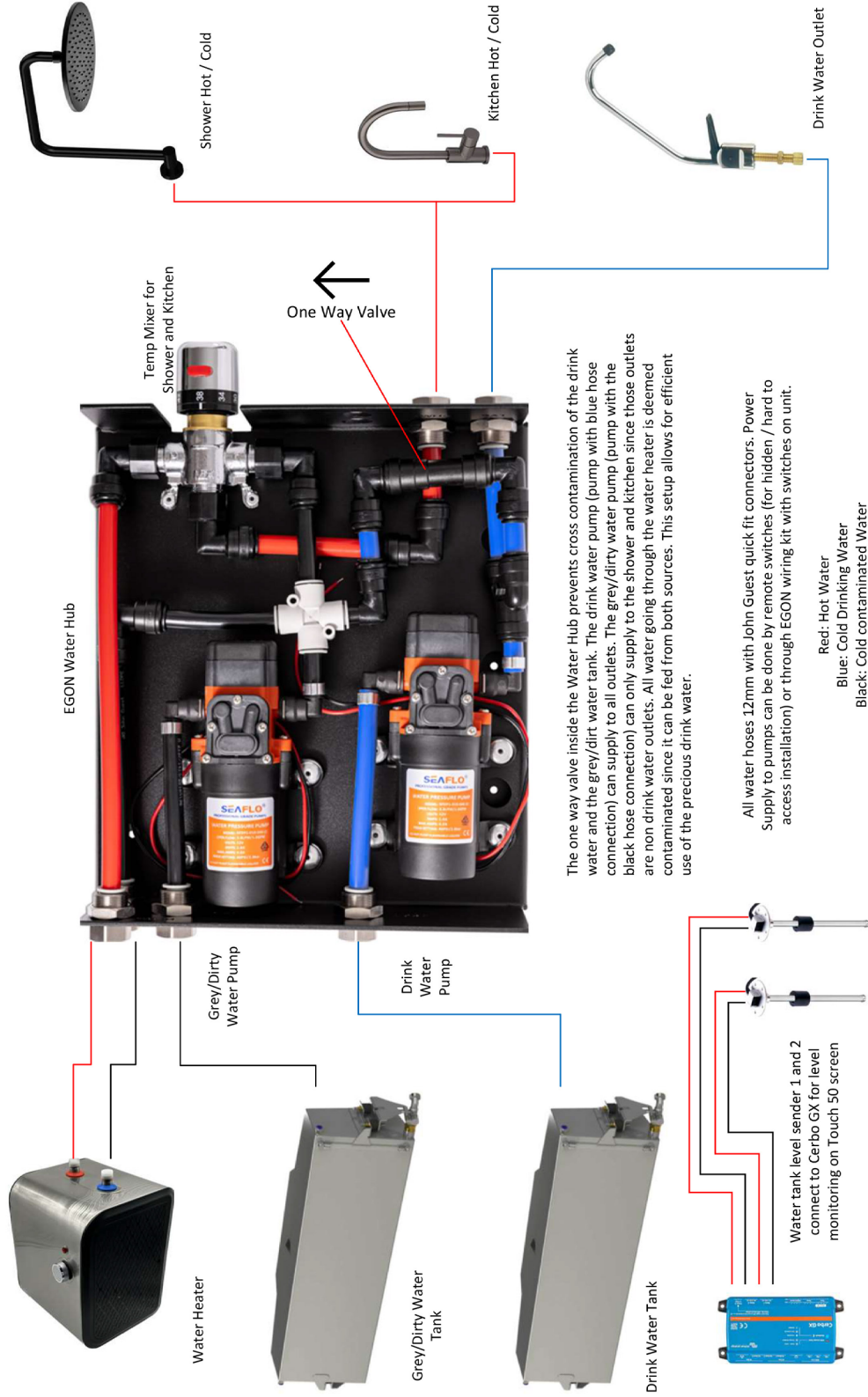

Water Plumbing and Water Level Circuits without EGON Water

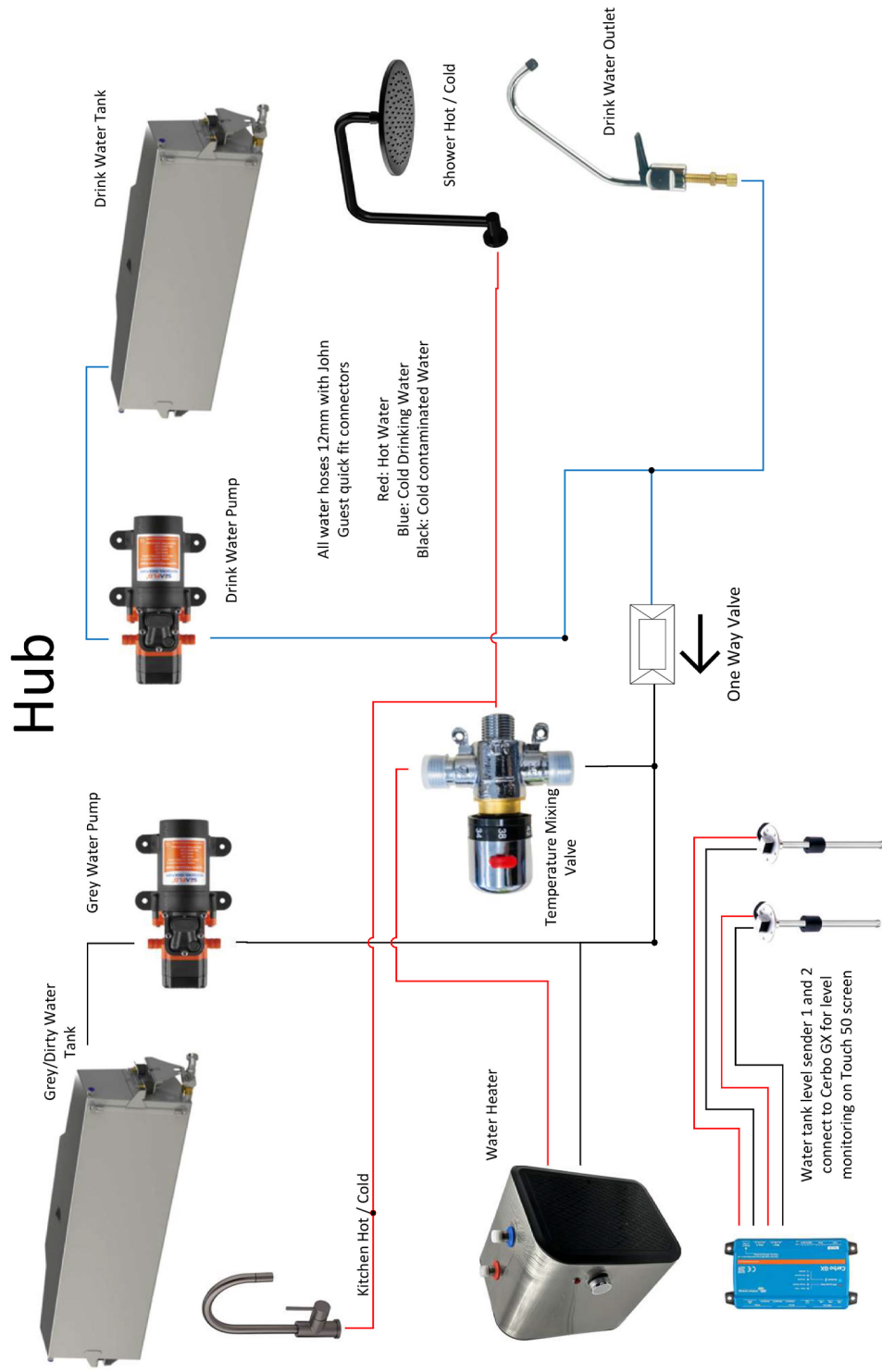

CONFIGURATION DATA AND DOWNLOADS

All settings can be found in the settings section. The Bluetooth connection can be found under the Device section and all settings for the charging system in the configure section.

After connecting to the Wakespeed unit you can always monitor the alternator controller status and internal parameters, even during operation, in the monitor section.

Connect To Wakespeed Controller via Bluetooth after installing the Wakespeed App on your phone. Make sure the control light on the unit is on. All cables need to be connected according to the wiring diagram and all fuses need to be installed and Vehicle Accessories turned on to power up the unit.

The following pages present a list of panels seen on the Wakespeed app configuration pages with recommended settings. Please set these exactly as described here. Please do not modify these unless you really know what you are doing.

In settings, Expert Mode needs to be turned on.

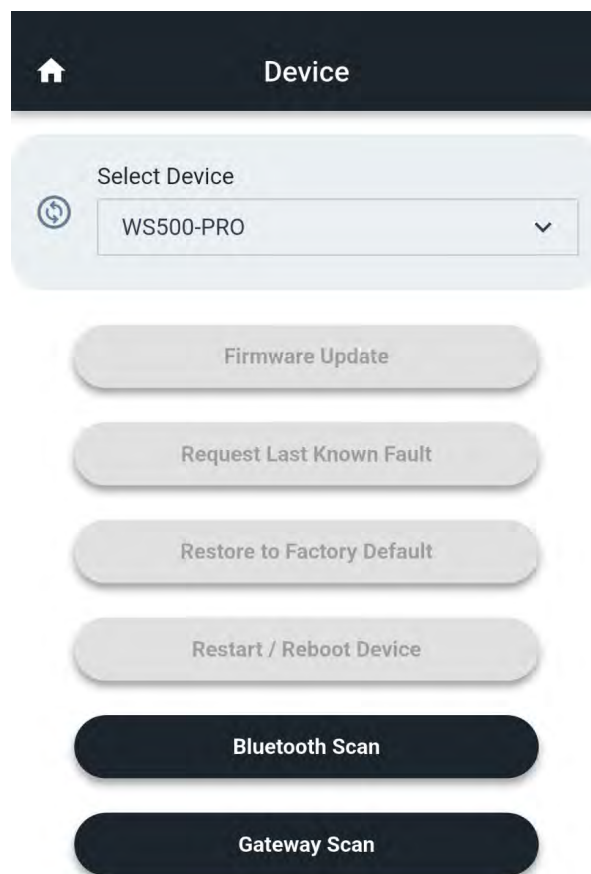
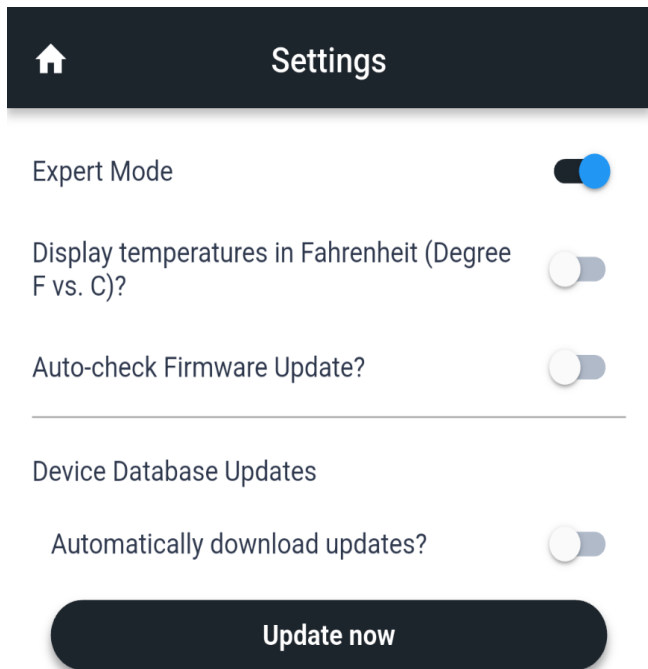

WAKESPEED. CONFIGURATION-1

The Alternator Name can be made anything you would like it to be. If in doubt, call it EGON_Alternator.

The temperature setting here is very important and can be increased to a max of 95°C if the unit tends to derate too much while running.

The setting Sense RPMs via stator wire can be activated if you choose to monitor the alternator / engine rpm with the Wakespeed regulator for display on the Cerbo GX screen. You will also need to adjust the harmonic balancer circumference to alternator pulley circumference ratio on this page when you enable this mode. Please see Wakespeed manual for more detail.

The screenshot shows the 'Wakespeed100percent' configuration interface. At the top, there are three tabs: 'Alternator', 'Battery', and 'System'. The 'Alternator' tab is selected. Below the tabs, the title 'Select an Alternator' is displayed. The form includes the following fields and controls:

- Brand:** A dropdown menu with 'Generic' selected.
- Model:** A dropdown menu with 'CUSTOM' selected.
- Instruction:** A blue arrow icon followed by the text 'You MUST enter the custom Alternator Voltage'.
- Alternator 'Voltage':** A text input field containing '48' with the unit 'volts (0 = Auto select)'.
- Alternator Capacity:** A text input field containing '100' with the unit 'Amps'.
- Alternator Name:** A text input field containing 'EGON_Alternator'.
- Alternator Temperature Setpoint:** A text input field containing '90' with the unit '°C'.
- Repurpose BTS as 2nd ATS?:** A toggle switch that is currently turned off.
- Save Configuration:** A large black button at the bottom.

The screenshot shows the 'Wakespeed100percent' configuration interface with the 'Advanced' settings for the alternator. The 'Alternator' tab is selected, and the name 'EGON_Alternator' is displayed at the top. The settings include:

- Alternator Temperature Setpoint:** A text input field containing '90' with the unit '°C'.
- Repurpose BTS as 2nd ATS?:** A toggle switch that is currently turned off.
- Adjust max field drive?:** A toggle switch that is currently turned on.
- Max field drive (Normal):** A text input field containing '100' with the unit '%'. This field is highlighted in pink.
- Max field drive (Small Alt Mode):** A text input field containing '100' with the unit '%'.
- Max field drive (Half Power Mode):** A text input field containing '50' with the unit '%'.
- Disable Fast Ramp?:** A toggle switch that is currently turned off.
- Sense RPMs via Stator Wire?:** A toggle switch that is currently turned off.
- Use RPMs to select Half Power mode?:** A toggle switch that is currently turned off.
- Save Configuration:** A large black button at the bottom.

WAKESPEED. CONFIGURATION-2

The setting for the Battery Capacity can be left at 100Ah. Since the battery state of charge is not measured by the Wakespeed, it needs to be left at 100Ah for the rest of these settings to work. Changing the 100Ah to a different value will also change other settings.

This is an overview of the charge settings which will be adjusted toward the end of this document.

The screenshot shows the 'Wakespeed100percent' app interface. At the top, there are navigation icons for 'Alternator', 'Battery', and 'System'. The 'Battery' tab is selected. Below the navigation bar, the title 'Select a Battery' is displayed. There are three dropdown menus: 'Brand' set to 'Generic', 'Model' set to 'CUSTOM', and 'Battery Ah Capacity (Each)' set to '105'. Below these is a 'Total number of batteries' field set to '1'. A warning message is shown: 'User defined Charge Profile' with a blue pencil icon. At the bottom, there is a '+' and '-' icon for adding or removing battery banks, and a summary: 'Your Battery Bank: 48 V, 105 Ah'. A detailed warning message is also present: 'WS500 Default Charge Profile. Customer modifiable, Generic LiFeP04 profile. Feature-in forces regulator to Float mode, Warning: careful attention to overall system design is needed when using generic LiFeP04 batteries.'

The screenshot shows the 'Wakespeed100percent' app interface for 'Charge Settings'. At the top, there are navigation icons for 'Alternator', 'Battery', and 'System'. The 'Battery' tab is selected. Below the navigation bar, there is a '+' and '-' icon for adding or removing battery banks, and a summary: 'Your Battery Bank: 48 V, 100 Ah'. A warning message is shown: 'WS500 Default Charge Profile. Customer modifiable, Generic LiFeP04 profile. Feature-in forces regulator to Float mode, Warning: careful attention to overall system design is needed when using generic LiFeP04 batteries.' Below this is a table of charge limits:

	Bulk Accept	Overcharge	Float	Equalize
Limits	56.0V		56.0V	
Exit Criteria	10A			

Below the table is a section titled 'TEMPERATURES' with the following settings:

Comp	
Min Charge	0°C
Max Charge	60°C

Below that is a section titled 'CHARGE CURRENT' with the following settings:

Max Charge Amps	100A
Reduced Amps	
Low Temp	< 0°C
High Temp	> 60°C
Low Volt	

WAKESPEED. CONFIGURATION-3

CPA are the settings for Charge Profile Accept.

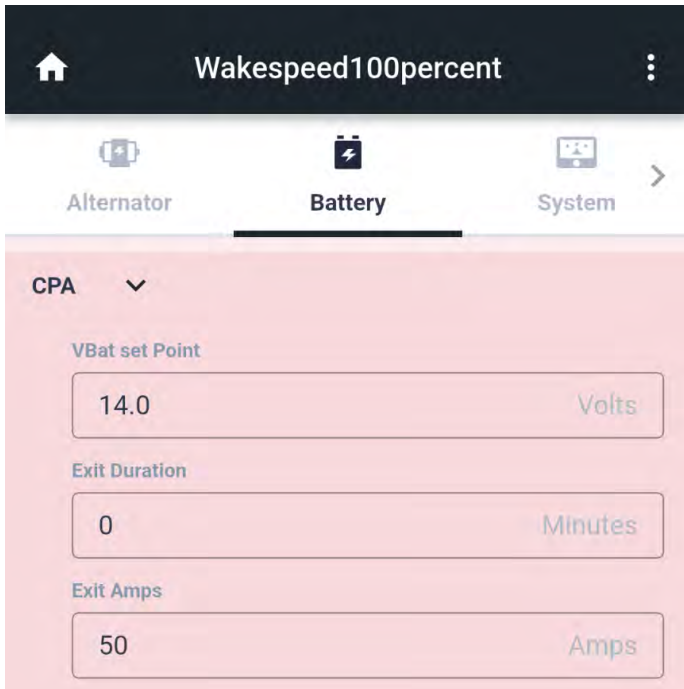

CPF stands for Charge Profile Float. It is used to keep the charge voltage stable at 56 Volt (4x14 Volt) for 30 minutes to allow for battery internal cell balancing.

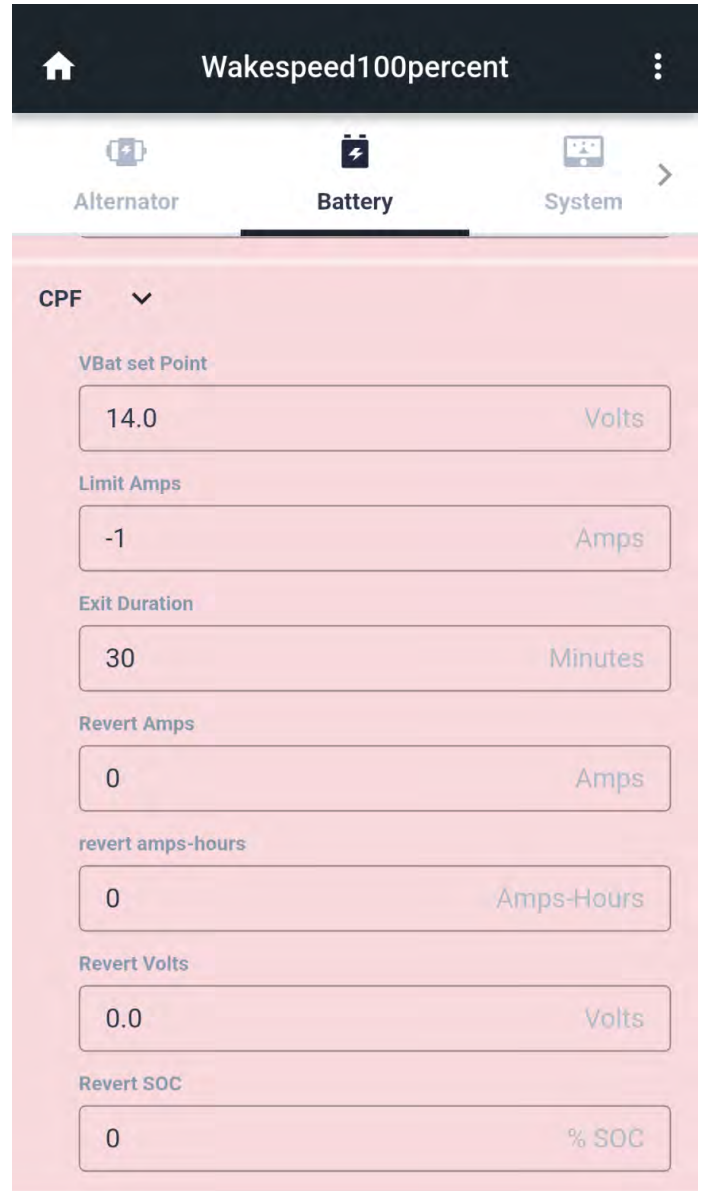

CPO stands for Charge Profile Overcharge. This profile is unused and can be left at 0.

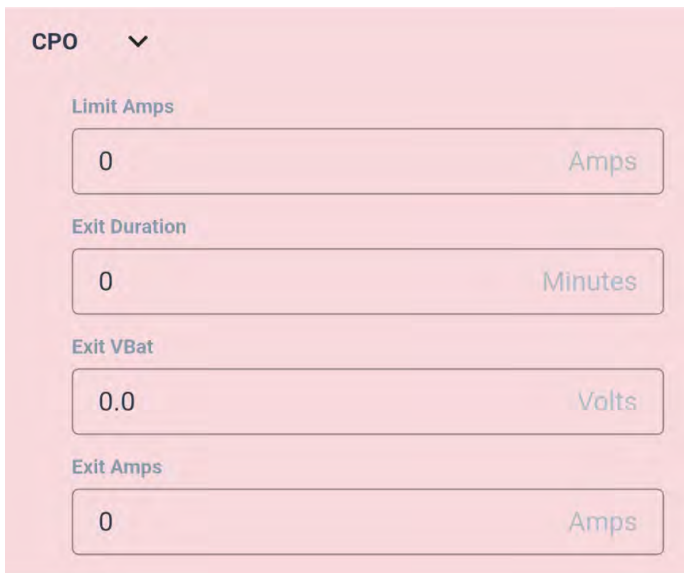

This is an overview of the charge settings which will be adjusted toward the end of this document.

WAKESPEED. CONFIGURATION-4

IMPORTANT.

Only charge the battery to 56 Volt (4 x 14 Volt). Do not charge the battery to its full capacity with the full 5kW charge power. This will result in over-voltage faults, since the alternator regulator cannot dial the power back fast enough. The last 3 to 5 % of capacity should be left uncharged, which will extend battery life, and can easily be topped up with solar.

SOLAR SETTINGS

Set the solar charge voltage to 4 x 14.2 Volt (56.8 Volt). By setting the solar voltage slightly higher than the alternator voltage will make sure that solar power has priority over alternator power when the battery is fully charged. It is recommended to set the solar voltage 4 x 0.2 Volt (0.8 Volt) higher than the alternator voltage. This will save fuel!

CPP stands for Charge Profile Post Float. This is the battery float voltage setting. It can be reduced to 13.5 Volt is necessary.

CPE stands for Charge Profile Equalisation. This profile is unused. All settings to 0.0

The screenshot shows the 'Battery' settings screen with the following configuration:

- CPP: 240 Minutes
- Revert VBat: 13.2 Volts
- Revert Amp-Hours: 0 Amp-Hours
- VBat set Point: 13.6 Volts

The screenshot shows the 'Battery' settings screen with the following configuration:

- CPE: 0.0 Volts
- Maxs Amps: 0 Amps
- Exit Duration: 0 Minutes
- Exit Amps: 0 Amps

WAKESPEED. CONFIGURATION-5

CPB is for battery specific settings regarding temperature compensation. In very cold environments (below 0°C) battery temperature, it might be necessary to reduce the charge current when charging the battery. Please refer to the Wakespeed manual and the battery specification for the necessary setup.

We are setting the battery charge parameters to work between 0 and 60°C. These settings will only take effect if you connect a battery temperature sender.

The maximum battery amps will be set to 100 Amp when you enter 500 Amp. For better understanding of the logic behind this please consult the Wakespeed manual.

Set the maximum battery voltage slightly below the maximum allowed voltage to make sure the Wakespeed stops charge immediately before tripping the battery internal BMS at 4 x 14.6 Volt.

CPB ▾

VBat Compensation

0.0 Volts per °C

Minimum Compensated Temperature

0 °C

Minimum Charge Temperature

0 °C

Maximum Charge Temperature

60 °C

RDC Volts

0.0 Volts

RDC Low Temp

0 °C

RDC High Temp

60 °C

RDC Amps

0 Amps

Minimum Charge Temperature

0 °C

Maximum Charge Temperature

60 °C

RDC Volts

0.0 Volts

RDC Low Temp

0 °C

RDC High Temp

60 °C

RDC Amps

0 Amps

Maximum Battery Amps

500 Amps

Maximum Battery Volts

14.5 Volts

WAKESPEED. CONFIGURATION-6

The shunt settings here set the alternator shunt that is installed on the EGON Hub 48-Volt. (In case you install the alternator current sense cables from the Wakespeed to the 48 Volt Hub the wrong way around, you can enable the Shunt Backwards Option.)

Battery System Engine

Will you install a current shunt at the Battery?

Will you install a current shunt on the Alternator?

Is shunt backwards?

Shunt Ratio (Amps/mV)

200A / 75mV

Enable Wireless Communications?

System Password

1234

Select a BMS

Brand

None

Define max current per BMS

0 Amps

Save Configuration

The alternator temperature sender is necessary for the safe operation of the system. The option sensor required for the alternator temperature sender (ATS) needs to be activated.

The Feature In wire is not required and can be ignored.

When using a battery with a smart BMS that can communicate with the Wakespeed and Cerbo GX via CAN BMS, the option Victron DVCC can be activated. That way the battery can control the charge current and voltage. In case the communication fails, the setup will revert back to the settings programmed into the Wakespeed Controller.

Battery System Engine

Support Victron DVCC?

Advanced Options

Do you wish to define Sensors which should be required?

Do you wish to define Sensors to be ignored?

Ignore the ATS Sensor(s)?

Ignore the BTS Sensor?

Ignore the Local Current Sensor?

Ignore the Stator Wire?

Ignore the Feature-In Wire?

WAKESPEED. CONFIGURATION-7

IMPORTANT

Battery disconnect voltage is the voltage that the controller will regulate to (4 x 13.5 Volt) when no battery is connected. This setting is important to activate a LiFePO4 battery that has switched off because it has become 100% discharged.

The screenshot shows the 'System' tab selected in the configuration interface. The settings are as follows:

- DC Disconnect Battery Voltage:** 13.5 Volts
- System Watts limit:** 0 Watts
- Select System Lockout option (See \$SCO: command):** No Lockout (default)
- Regulator Options:**
 - Regulator Device Instance:** 1
 - Regulator Device Priority:** 70
 - How should the Feature-In line behave when activated?:** Default
 - How should the Feature-Out line behave?:** Lamp (Blinks out Fault #)
- Auto restart on most hard faults?:** Enabled (toggle switch)

Auto restart on most hard faults is very important. In case the wakespeed controller detects a fault like a over-voltage scenario, it will send an audible alarm to the beeper on the EGON Hub 48-Volt and then restart the unit after a few seconds, without the need to power cycle the unit. The setting LAMP (Blinks out Fault #) makes sure the audible alarm is a beep code that represents a fault code. Consult the Wakespeed manual for details. The alarm will also be displayed on the Victron Touch-50 screen with a more precise explanation.

The screenshot shows the 'Engine' tab selected in the configuration interface. The settings are as follows:

- Engine Options:**
 - Engine Warmup Delay:** 15 Seconds
 - Engine ID (Instance):** 0

WAKESPEED. CONFIGURATION-8

These settings are for the setup of the CAN communication with the Victron Cerbo GX unit.

After finishing the setup, please save your configuration file and then use the configure device feature to program the settings into the Wakespeed controller. After that, you can go to the monitor section, start the engine (after making sure it is safe to do so) and watch the system operating.

The screenshot shows the 'Engine' configuration tab with the following settings:

- Battery ID (instance):** 1
- Select CAN Baud Rate:** Default (250 kbps)
- Enable OSEnergy (RV-C) CAN subsystem?**
- Allow regulator to act as Battery Master?**
- Ignore remote CAN based battery capacity data?**
- Enable Alternative CAN / BMS protocol?** Standard Only
- Enable NMEA2000 CAN subsystem?**
- Suppress sending N2K Battery messages?**
- Use N2K sensor for Alternator Current?**

Save Configuration

Nothing to setup in this section below.

The screenshot shows the 'Engine' configuration tab with the following settings:

- Do you wish to define a maximum engine loading value?**
- Do you wish to define 'White Space' load shaping?**
- Do you wish White Space to always be enabled? (vs. only when Feature-in is active)**
- Enter max engine-RPMs:** 3600 RPMs
- Please check the box to Unlock White Space sliders for adjusting:**

0	450	900	1350	1800	2250	2700	3150
450	900	1350	1800	2250	2700	3150	3600

Select a DCDC Converter

- Brand:** Wakespeed
- Model:** None
- Mode:** Disabled

CERBO GX CONFIGURATION

IMPORTANT. I MEAN, REALLY IMPORTANT.

DON'T MIX THESE UP . . .

The RJ45 Data cable has a black and a blue side and it comes with a black and a blue terminating resistor. The black plugs are for the Wakespeed and the blue plugs for the Cerbo GX. **Mixing these up will destroy the Wakespeed controller!**

For more details on how to setup the Can Bus communication to the Cerbo GX please refer to the Wakespeed connection to CerboGX pdf manual.

Wakespeed-Victron-Cerbo-GX-Guide_4.29.24-1.pdf



Cerbo GX Settings

Set up Relay 1 and Relay 2 in the Cerbo GX settings to be manually controlled. Rename Relay 1 to Vehicle 12 Volt Supply and Relay 2 to Accessory 12 Volt Supply.

That way you can control the DC/DC converters from your Cerbo GX homescreen and turn them on and off even when the key is not in the ignition. This can also be done remotely through an app to charge your start battery periodically when the vehicle is in storage.

It can also be used to recharge a flat start battery. The DC/DC converter for the vehicle 12-volt supply can also be used as a jump start feature either through the override function in the Cerbo GX or just by turning on accessories.

DC-HUB 48V FUSE GUIDE



Vehicle owner/details:

Nr.	A	description
F1	10	12/24V OE Regulator Supply
F2	3	12/24V Buzzer/Lamp activation
F3	10	48V Alternator Supply - neg. regulated field
F4	30	48V Out/Input:
F5	30	48V Out/Input:
F6	10	48V Wakespeed Supply
F7	30	48V DC/DC-1 Supply:
F8	30	48V DC/DC-2 Supply:
F9	3	48V Cerbo GX Supply
F10	3	12/24-Volt Switch/Relay Supply
F11	80	48V Out/Input:
F12	80	48V Out/Input:
F13	150	48V Inverter Supply

POWER-DISTRIBUTION SIMPLICITY

RECOMMENDED TORQUE SETTINGS

Tightening screw terminals on the DC-Hub 48V properly is a VITAL step.

- 140A connector: 3Nm
- 80A/40A connectors: 1.8Nm

Don't forget to check screw tensions regularly for high-vibration applications.

COST QUESTIONS

We have compared 48V to what we see as the best value 12V system available, the one made by Victron, and Egon 48V is 3,2 times less costly per watt. The following comparison compares the costs of the highest output 12V Victron and Redarc systems with the EGON 48V system. Prices provided below reflect average retail in Australia. (May 2026)

Victron 12-Volt

Max Charge from alternator: 100A. Max charge from solar: 70A
TOTAL max charge: 170A, 2176 Watt. Cost: **± A\$12 586.20**

Redarc 12-Volt

Max Charge from alternator and solar are combined: 100A
TOTAL max charge: 100A, 1280 Watt. Cost: **± A\$15,794.00**

EGON 48-Volt

Max Charge from alternator: 100A @ 48V = 400A @ 12V equivalent.
Max charge from solar: 40A @ 48V = 160A @ 12V equivalent.
TOTAL max charge: 140A = 480A @ 12V equivalent, 7168 Watt
Cost: **± A\$13,823.60**

12V IS DYING

Because of its efficiency, military vehicles have been using 48V for decades. But until now, complexity and costs have prevented it being a viable alternative for RV users. In 2026 Egon changed that. Using EGON's well-proven PCB board technology as the distribution hub, with protection and redundancies built into that board, the Egon DC-Hub 48V brings 48V to everyone who wants the massive improvements in battery charge speeds and exceptional energy efficiency only available to those operating at 48V or higher. 12V is dying. And EGON is killing it!

Out of the box simplicity.

That's the beauty of EGON. You don't need to be an expert to get the most out of ANY EGON PRODUCT. We've designed our solutions so that every installer gets it right first time, every time without the technical know-how you think you need to succeed.

So, no matter who you've got on the installation – you can trust that the job will be done effectively, quickly and all whilst maintaining the specifications you need to uphold regulations. Oh, and increasing your productivity and profits in the meantime.

That's a win win, if ever we saw one.

DO YOU WANT TO BE PART OF THE REVOLUTION?

WELCOME to the EGON Renegade Network.

This is a growing community of EGON Partners around the globe. These companies are Renegades in their field and are pushing the boundaries of vehicle based service systems with innovation and attention to detail.

EGON Renegades are at the cutting edge of what is possible with a strong focus speeding up installations and improving reliability. Changing the market through EGONs Game Changing Simplicity approach with circuit board based power distribution.

Ready to Join the EGON Renegade Network?:

As an EGON Partner, you'll receive installation and sales training for EGON products, plus the opportunity to be featured on our social channels as a new member of the network.

Join now : <https://egon.com.au/pages/egon-renegade-network>

**GAME-CHANGING
SIMPLICITY**

Support Email: support@egon.com.au

Online Guides and Information: egon.com.au